

Technical documentation

Thin section bearings with polished raceways type LSA



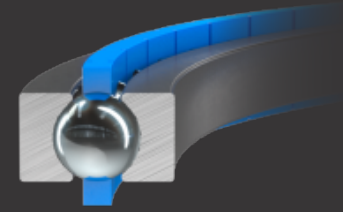

Table of contents

	page		page
1. Type LSA		5. Rotational resistance and concentricity	10
1.1 Overview	3	6. Assemble gaskets	11
2. Calculation basis		7. Maintenance	
2.1 Terms, unit of measurement.....	4	7.1 Safety instructions for maintenance	12
2.2 Static calculation	4	7.2 Maintenance work	13
2.2.1 Axial and radial factors		7.2.1 Relubrication	
2.2.2 Recommended static safety S_{st}			
2.3 Dynamic calculation.....	5	8. Tools and accessoires	
2.3.1 Nominal lifetime		8.1 Tools needed.....	15
2.3.2 Axial and radial loads		8.2 Accessoires.....	15
2.3.3 Axial and moment load and axial load with $F_r = 0, M_k = 0$		9. Imprint	15
2.3.4 Radial and moment load and radial load with $F_a = 0, M_k = 0$			
3. Construcion wire bed	6		
3.1 Construction examples.....	7		
4. Assembly	8		

1. Type LSA

1.1 Overview

Size	Representation
<p>LSA 4</p> <p>d 4.0 - 15.0 inch</p>	
<p>LSA 6</p> <p>d 4.5 - 15.0 inch</p>	
<p>LSA 8</p> <p>d 5.5 - 30.0 inch</p>	

2. Calculation basis

All forces and moments acting on the bearing are to be summarized by vectorial addition into centrally acting forces F_a and F_r as well as resulting moments M_k . For complex load cases and load collectives with variable load and speed, we will be pleased to perform the calculation for you.

2.1 Terms, unit of measurement

C	dynamic load rating	(N)
C_0	static load rating	(N)
F_a	centrally acting axial force	(N)
F_r	centrally acting radial force	(N)
KKØ	Ball race diameter = (D + d)/2	(M)
L_n	nominal life	(h)
M_k	tilting moment	(Nm)
n	rotational speed	(min - 1)
P	dynamic equivalent load	(N)
P_0	statically equivalent load	(N)
S_{st}	static safety	
X	Radial factor	
Y	Axial factor	
Z	Moment faktor	

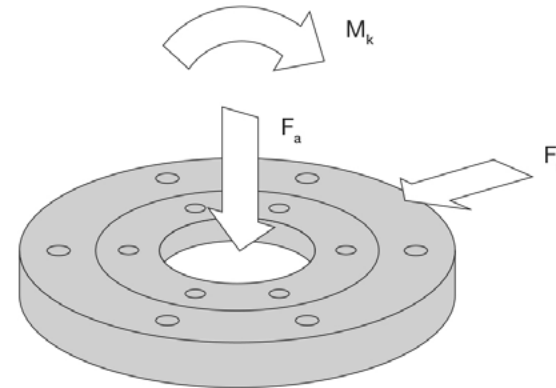

2.2 Static calculation

A static calculation is sufficient if the bearing is loaded at standstill. A bearing with sufficient load carrying capacity has been selected if the recommended static safety is achieved.

$$S_{st} = \frac{1}{\frac{F_a}{C_{oa}} + \frac{F_r}{C_{or}} + \frac{M}{C_{om}}}$$

2.2.1 Axial and radial factors

	X_0	Y_0
All bearing types	1.0	0.47

2.2.2 Recommended static safety S_{st}

Ball diameter > 6	S_{st}
With quiet, vibration-free operation	> 1.8
During normal operation	> 2.5
With pronounced shock loads and high requirements on running accuracy	> 8.0

2.3 Dynamic calculation

For a circulating speed of $v > 0.1$ m/s, a static and dynamic calculation is required, whereby the static safety S_{st} must reach at least the recommended value of the respective load (Table 2.2.2).

2.3.1 Nominal life

$$L_n = \left(\frac{C}{P}\right)^3 \cdot \frac{10^6}{60 \cdot n} \quad (h)$$

2.3.2 Axial and radial loads

$$P = X \cdot F_r + Y \cdot F_a \quad (N)$$

	$\frac{F_a}{F_r} \geq 1$		$\frac{F_a}{F_r} < 1$	
	X	Y	X	Y
All bearing types	1.26	0.45	0.86	0.86

2.3.3 Axial and moment load and axial load with $F_r = 0, M_k = 0$

$$P = Y \cdot F_a + Z \cdot \frac{M_k}{KKØ} \quad (N)$$

	$0 < \frac{M_k}{F_a \cdot KKØ} \leq 0,5$		$\frac{M_k}{F_a \cdot KKØ} \geq 0,5$	
	Y	Z	Y	Z
All bearing types	0.86	1.72	0.45	2.54

2.3.4 Radial and moment load and radial load with $F_a = 0, M_k = 0$

$$P = X \cdot F_r + Z \cdot \frac{M_k}{KKØ} \quad (N)$$

	$0 \leq \frac{M_k}{F_r \cdot KKØ} \leq 0,5$		$\frac{M_k}{F_r \cdot KKØ} \geq 0,5$	
	X	Z	X	Z
All bearing types	1.0	1.68	0.86	1.96

We will be pleased to perform the calculation for you for the load case radial, axial and moment load.

3. Construction wire bed

In contrast to the bearing elements LEL and LER, the bearing elements LSA are not adjustable and are basically subject to play. According to the following specifications, the resulting bearing arrangements have clearance between 0.02 and 0.08 mm. The wire bed is undivided, an adjustment of the clearance is not possible.

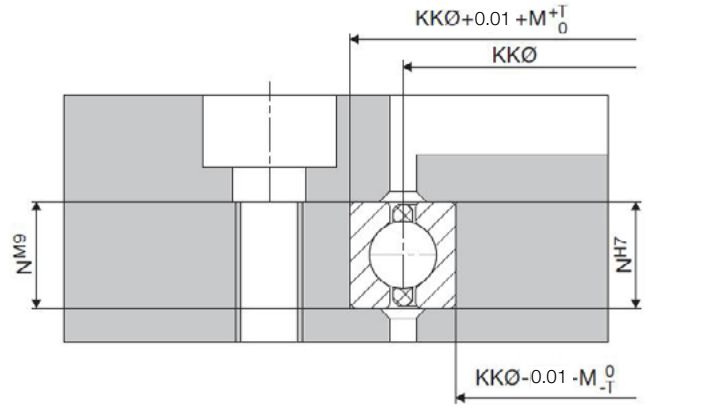

LSA 4

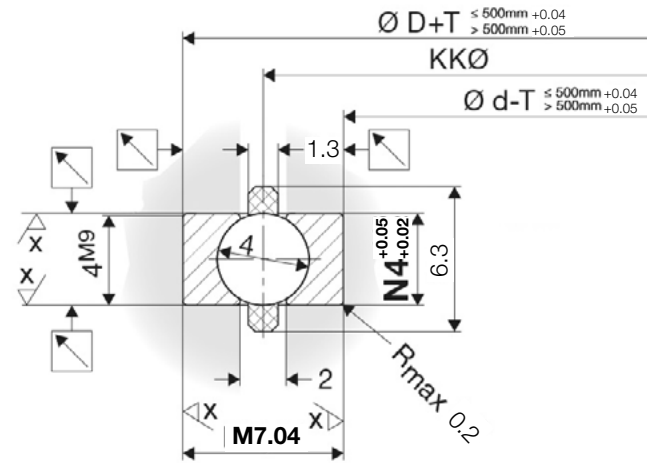

LSA 6

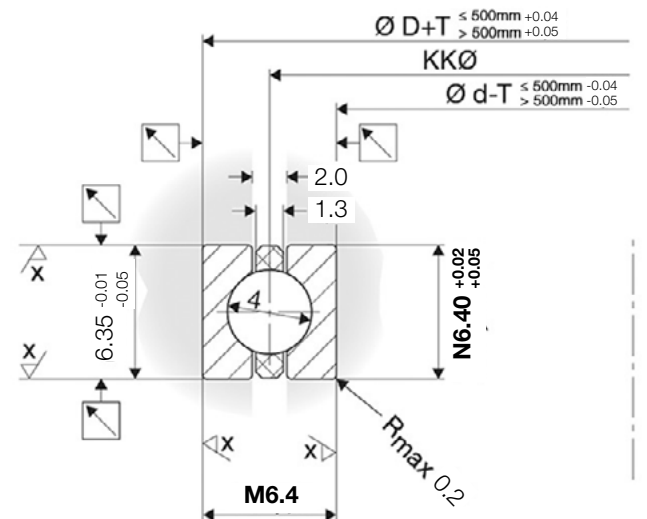

LSA 8

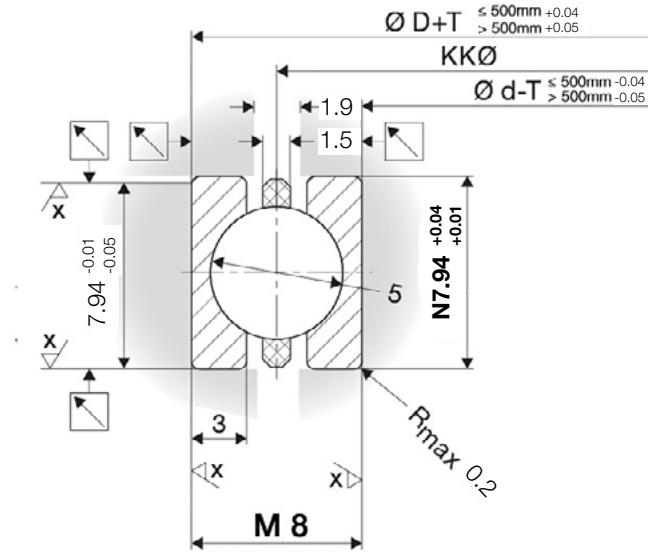

The wire bed has no radii which accommodate the race. However, care must be taken in the design that the tool radii are not greater than 0.2 mm.

From a design point of view, it makes sense to design the outer ring of the bearing as split, this increases the ease of mounting. The accuracy to be achieved is influenced by the individual accuracies.

The roundness of the wire bed is generally based on half the diameter tolerance, and the bolt-on surface of the adjacent construction is used as the basis for the axial runout of the wire bed. The basis for radial runout is generally the centerline of the wire bed.

Flatness and parallelism of the individual parts are designed with half of the total tolerance. It is sufficient to produce the wire bed by turning or milling. Surface finishes of $R_a < 3.2$ should be aimed for, since the setting behavior of the bearing is positively influenced by a high surface finish.

3.1 Construction examples

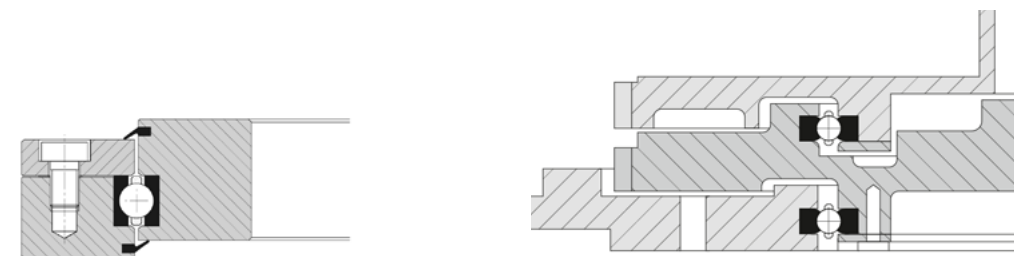

4. Assembly

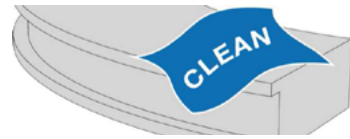

Clean components

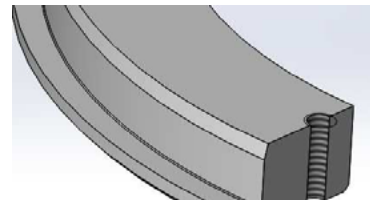

Grease components

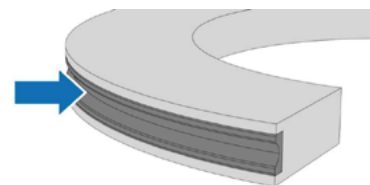

Insert bearing

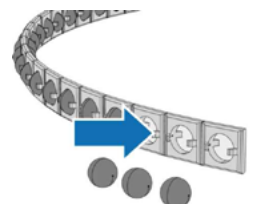

Press rolling elements into cage

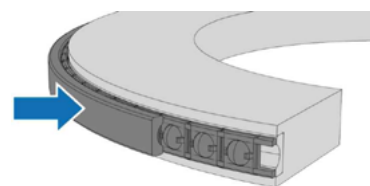

Place cage and outer ring

1 Clean components with a clean, lint-free cloth.

2 Type LSA: Grease the races (rear side)

Type LSA with elastomer: Lightly grease bearing seat

3 Type LSA: Insert the inner ring of the raceway into the inner ring of the adjacent construction. Make sure that the race ends are separated by a gap.

4 Press rolling elements into the band cage (if necessary)



Only use the balls enclosed in the delivery. If balls are lost, all balls must be replaced so as not to impair the running properties and functionality of the bearing.

For recommended lubricants, see page 15.

5 Place the cage and the outer race on the inner race as shown in the figure „Pressing the rolling elements into the cage“. Hold the race ends of the outer race together so that the ball cage cannot slip out.

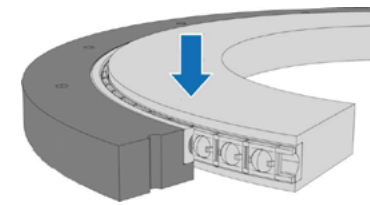

Place outer ring

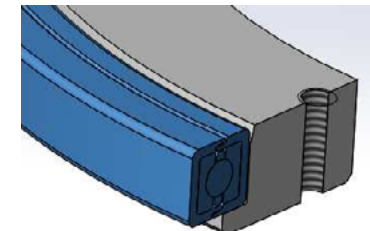
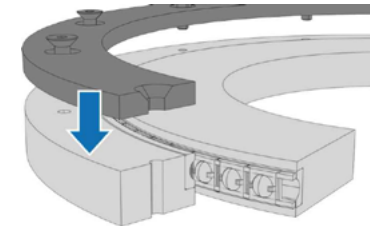

LSA with elastomer

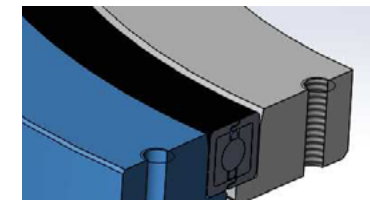

Put on lid

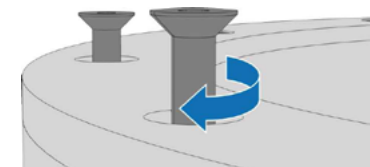
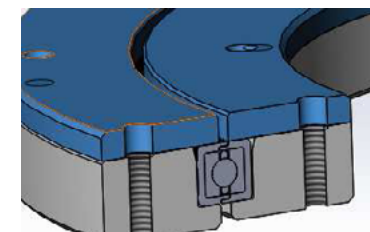

6 Position outer ring and push in axially

7 Put on lid

LSA with elastomer: Slide the thin-section bearing onto the inner ring of the adjacent construction. Make sure that the elastomer profile is not damaged.

LSA with elastomer

8 Screw



Tuning by means of shims or solid tuning is not required.
Type LSA: The bearing has a clearance of + 0.05 mm to + 0.1 mm. If necessary, the clearance can be reduced by +/- 0.02 mm by sorting the balls.

Tolerances for the overall height

Size	split ring (mm)	unsplit ring (mm)
LSA 4	-0.03 bis 0	+0.02 bis +0.05
LSA 6	-0.05 bis -0.01	+0.02 bis +0.05
LSA 8	-0.05 bis -0.01	+0.01 bis +0.04

Tolerances for the outside/inside diameter

$D + T \leq 500 \text{ mm}$	+0.04 mm	$d - T \leq 500$	-0.04 mm
$D + T \geq 500 \text{ mm}$	+0.05 mm	$d - T \geq 500$	-0.05 mm

5. Rotational resistance and concentricity

The following data are recommendations of the rotational resistance to be set. Depending on the manufacturing tolerances, the concentricity accuracies shown can be achieved.

LSA 4 / 6

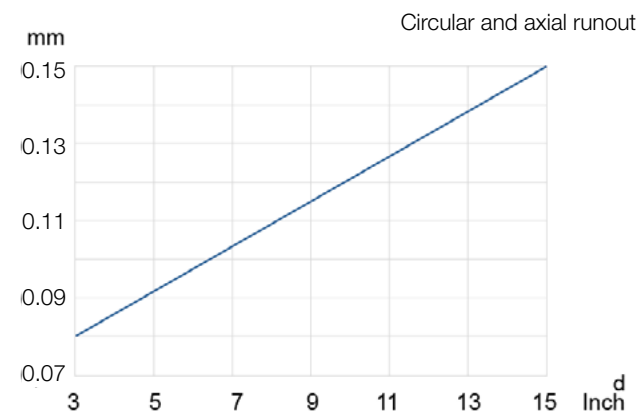
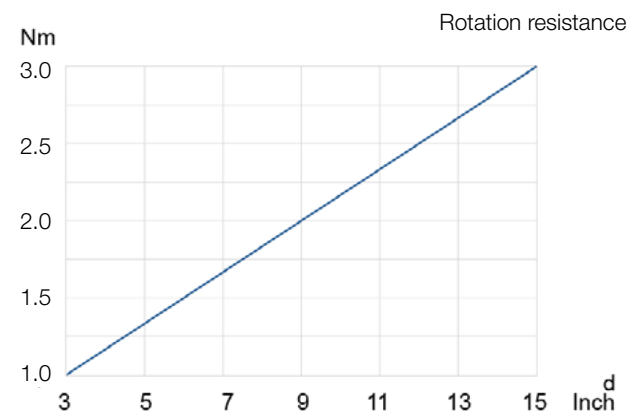

LSA 8

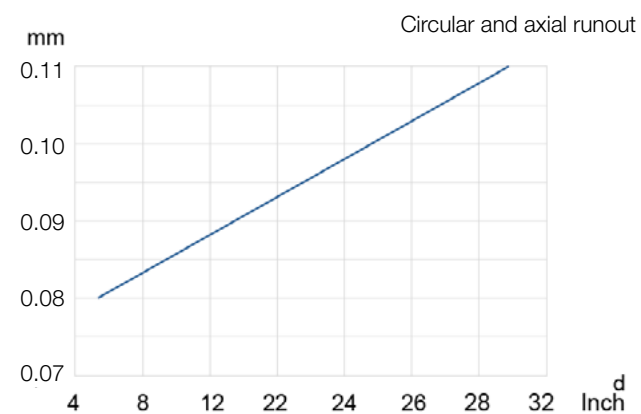
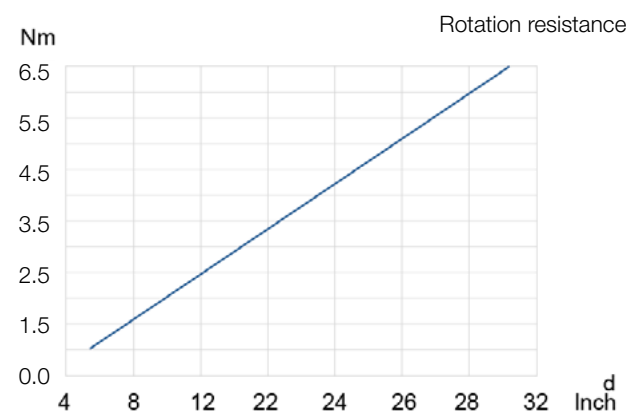

6. Mount gaskets

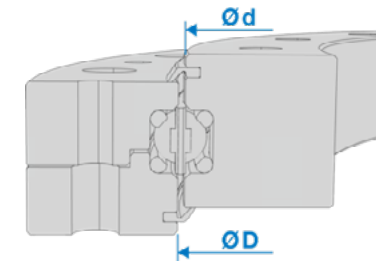

Calculate gasket length

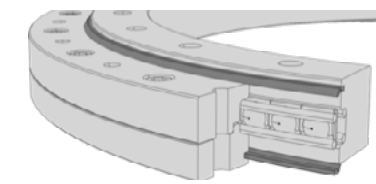

Gasket length

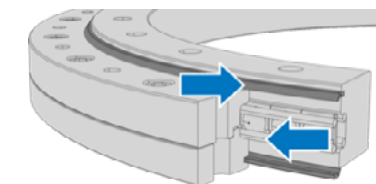

Insert gasket

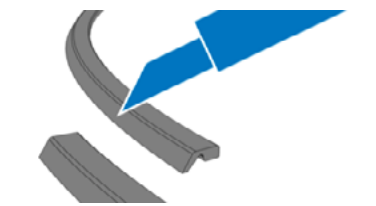

Cut off protruding ends

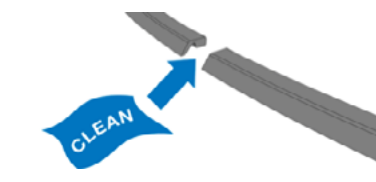

Clean cut edges

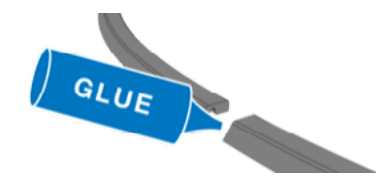

Gluing the separation points

- 1 Use the following formula to roughly calculate the gasket length.

$$\begin{array}{l} \text{Inner ring} \qquad \qquad \qquad d * \pi + 25 \text{ mm} \\ \text{Outer ring} \qquad \qquad \qquad D * \pi + 25 \text{ mm} \end{array}$$

- 2 Determine exact gasket length.



The formula for determining the gasket length gives a guide value. The final length of the gasket is determined when the gasket is inserted into the gasket groove.

- 3 Insert gaskets.

- 4 Cut off protruding ends of the gasket to the appropriate length.



Cut gasket exactly perpendicular to length to create exact joints for gluing.

- 5 Remove the seal from the seal groove and clean the separation points so that they are completely free of grease.

- 6 Coat one of the separation points with a suitable glue (e.g. Loctite 401).

- 7 In case of using an FKM gasket (Viton), an activator is required (e.g. primer Loctite 770).

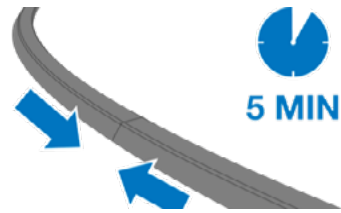

Press glued joints together

- 8 Press the joints together for approx. 20 seconds and allow the glue to cure for 5 minutes. Then remove any excess and glue residues.

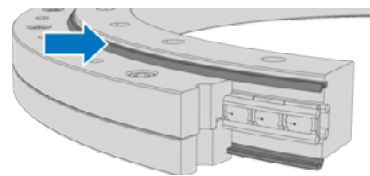

Insert gasket

- 9 Reinsert the seal into the groove.

7. Maintenance

7.1 Safety instructions for maintenance

Improper
Maintenance work

WARNING!

Risk of injury due to improperly performed maintenance work!

- Ensure sufficient assembly clearance before starting work.
- Ensure tidiness and cleanliness at the assembly site!
- If components have been removed, ensure correct assembly, reinstall all fasteners and observe screw tightening torques.
- When cleaning the bearing, use suitable cleaning agents that are compatible with the seal. For this purpose, follow the instructions of the cleaning agent manufacturer.

Observe the following before recommissioning:

- Ensure that all maintenance work has been carried out and completed in accordance with the information and notes in this manual.
- Ensure that there are no persons in the danger zone.
- Ensure that all covers and safety devices are installed and functioning properly.

Incorrect maintenance

NOTE!

Material damage due to faulty maintenance

- Inspect slewing ring for corrosion every six months.
- Depending on the application (e.g. influence of vibrations), retighten the screw connections at regular intervals.
- If the bearing makes running noises, switch off the machine and determine the cause of the fault.
- Check the seals of the bearing at regular intervals.

Incorrect lubrication

NOTE!

Material damage to the bearing due to improper lubrication!

- Only use greases approved by the manufacturer (→ chapter 5.1 “Approved lubricants”).
- Observe relubrication quantity and relubrication intervals (→ chapter 8.2.1 “Relubrication”).
- Relubricate the bearing only at operating temperature.

Environmental protection

At all lubrication points supplied with lubricant, remove the escaping, used or excess grease and dispose of it in accordance with the applicable local regulations..

7.2 Maintenance work

7.2.1 Relubrication

Lubricants



For long-term lubrication, use high-performance bearing lubricants due to their higher ageing resistance. Franke recommends the special lubricating grease „SHELL Gadus S3 V220 C2“ or comparable.

NOTE!

Material damage due to improper lubrication!

- Ensure that the lubricants are suitable for the respective application and for the materials used (e.g. rolling bearing cage or seal).
- When mixing lubricants, consider the compatibility of the lubricant types. In particular, note the base oil type, thickener, base oil viscosity and NGLI class. These questions must be clarified in advance with the lubricant manufacturer, especially if the bearing is used under extreme operating conditions.

Relubrication of the bearing

Relubrication takes place via the gap between the inner and outer ring.

- 1 Perform relubrication below the operating temperature of the bearing.
- 2 When relubricating, rotate the bearing.



Relubrication



The relubrication period is application-specific. The following table shows reference values.

For recommended lubricants, see page 15.

Relubrication intervals

Peripheral speed in m/s	Relubrication interval in h
0 bis < 3	5000
3 bis < 5	1000
5 bis < 8	600
8 bis < 10	200

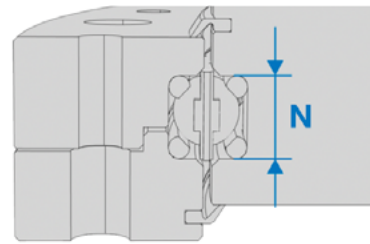

Wire bed height

- ③ Once the relubrication frequency has been determined, calculate the relubrication quantity using the following formula.

Relubrication quantity for bearing elements:

$$m = KK\varnothing \cdot (N \cdot 2) / 3 \cdot x$$

m = relubrication quantity in grams

∅KK = ball ring diameter

M = wire bed height in millimeters

x = factor x in mm⁻¹ according to table for relubrication quantity

Relubrication	x in mm ⁻¹
Weekly	0.002
Monthly	0.003
Yearly	0.004
Every 2 - 3 years	0.005



When lubricating toothed bearings, automatic gear lubrication is recommended. In the case of manual lubrication, lubricate the gearing and pinions before commissioning.

Always contact customer service in the event of any uncertainties.

Lubricants

Application area	Manufacturer	Description	Usage	Container	Order no.
Standard					
Universal applicable	Shell	Gadus	ex factory in all slewing rings of the standard series LVA, LVB, LVC, LVD, LVE, LVG	400g	45176
Special					
High dynamic	Klüber	Isoflex Topas NCA52	at high speeds or traversing speeds	1kg	10004
High temperature	Klüber	Barrierta L55/2	for temperatures in ranges up to max. +260°C	180g	06439
Food safe	Klüber	Klübersynth UH1 64-1302	Paraffin-free for use e.g. in food production or pharmaceuticals	400g	47612
Cleanroom compatible,	Klüber	Klüberalfa YV193-152	Special grease with high chem. stability for use in extreme atmospheric environments	1kg/50g	48055

8. Tools and accessoires

8.1 Tools needed

- Torque wrench
- Dial gauge
- Allen wrench
- Screwdriver
- Surface cylindrical grinding machine (for massive tuning)
- Feeler gauge
- Spring scale (or similar)
- Lever for measuring the torque

8.2 Accessoires

The following accessories are optionally available:

- Reconciliation supplements
- Seals
- Spare balls (G25 according to DIN 5401) for bearing elements
- Retaining screws

9. Impressum

© Franke GmbH
 Obere Bahnstr. 64
 73431 Aalen
 Tel. +49 7361 920-0
 info@franke-gmbh.com
 www.franke-gmbh.com

All rights reserved.
 No liability for errors or
 printing mistakes.

This manual is also as a
 download (PDF) on our website.
www.franke-gmbh.com/downloads