

Linear Modules

Type FTD

FTD 15-35

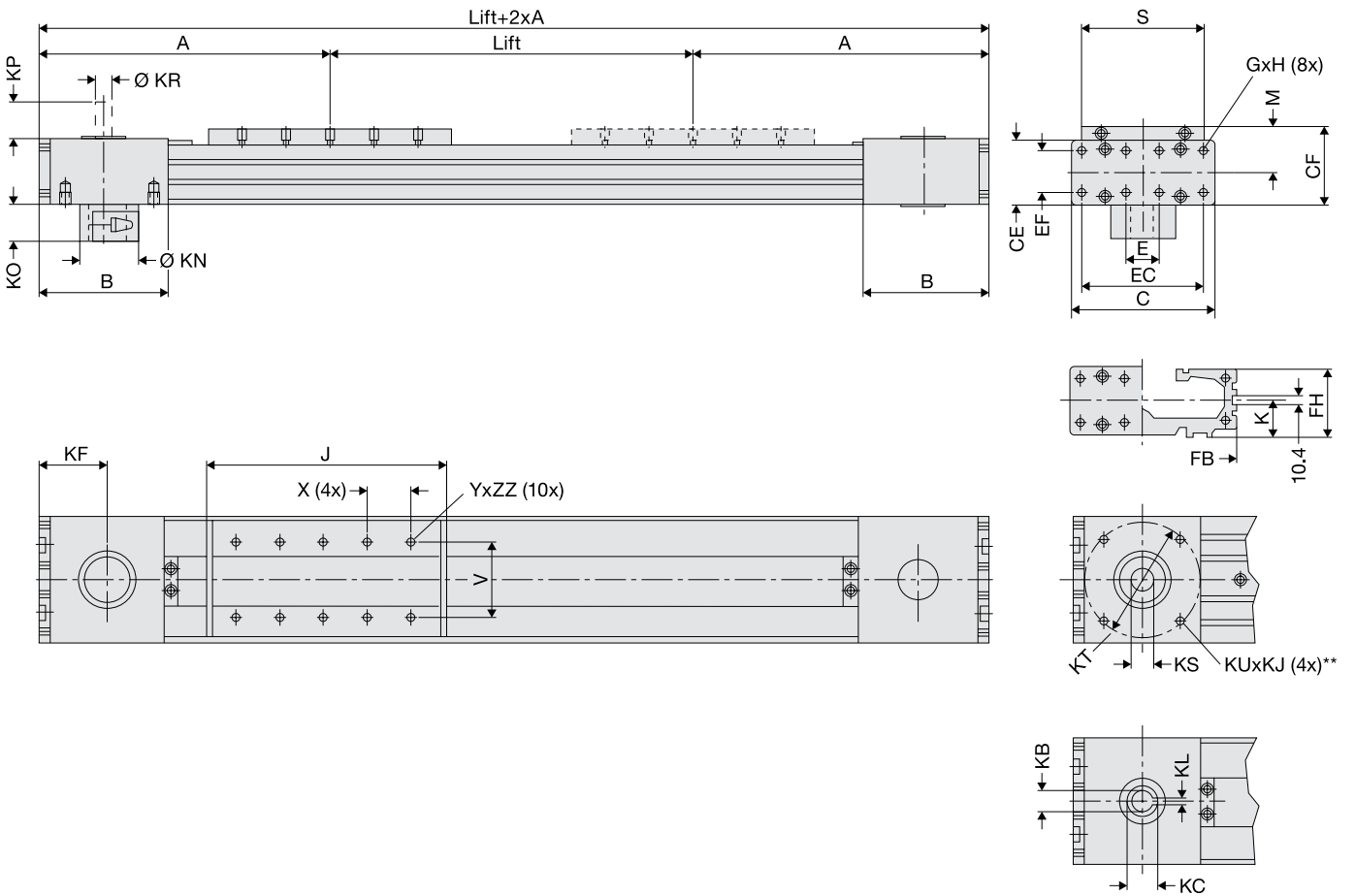

Optional: Sleeve shaft with feather key groove

Dimensions

Size	Dimensions												
	mm												
	A	B	C	E	G	H	J	K	M	S	V	X	Y
15	218	88	93	25	M5	10	178	21.5	31	85	64	40	M6
20	262	112	116	28	M6	12	218	28.5	38	100	64	40	M6
35	347	147	175	18	M6	12	263	43.0	49	124	90	60	M6

Size	Dimensions																		
	mm																		
	CE	CF	EC	EF	FB	FH	KF	KB*	KC	KL	KJ	KN	KO	KP	KR	KS*	KT	KU	ZZ
15	42	52.5	79	27	92	39.5	49.0	16 ^{H7}	18.3	5	8	34	21.7	30	16 ^{H7}	16 ^{H7}	82	M 8	8
20	56	66.5	100	36	116	51.7	62.0	22 ^{H7}	24.8	6	12	53	30.0	30	22 ^{H7}	22 ^{H7}	106	M10	10
35	87	92.5	158	70	164	77.0	79.5	32 ^{H7}	35.3	10	19	75	41.0	35	32 ^{H7}	32 ^{H7}	144	M12	10

Materials

	Body material	Balls	Wipers
Standard	High-strength, anodized aluminium	Antifriction bearing steel 100Cr6	Plastic plate with felt wiper
Special		Non-corrosive steel X12CrNi177	

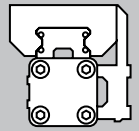

Stroke mm	Order no.		
	FTD 15 without motorisation	FTD 20 without motorisation	FTD 35 without motorisation
100	92900A	92925A	92950A
200	92901A	92926A	92951A
300	92902A	92927A	92952A
400	92903A	92928A	92953A
500	92904A	92929A	92954A
600	92905A	92930A	92955A
700	92906A	92931A	92956A
800	92907A	92932A	92957A
900	92908A	92933A	92958A
1000	92909A	92934A	92959A
1200	92910A	92935A	92960A
1400	92911A	92936A	92961A
1600	92912A	92937A	92962A
1800	92913A	92938A	92963A
2000	92914A	92939A	92964A
2500	92915A	92940A	92965A
3000	92916A	92941A	92966A
3500	92917A	92942A	92967A
4000	92918A	92943A	92968A
4500	92919A	92944A	92969A
5000	92920A	92945A	92970A
5500	92921A	92946A	92971A
6000	92922A	92947A	92972A
6500	92923A	92948A	92973A
7000	92924A	92949A	92974A

Performance overview

Load rating: stat. / dyn. Co / C	N	3400/4200	5400/5400	18000/12500
Max. torque (MCX / MCY, MCZ)	Nm	45/274	76/460	294/1233
Max. speed	m/s	10	10	10
Max. acceleration/deceleration	m/s ²	40	40	40
Max. effective power FX < 1 m/s	N	1070	1870	3120
at speed 1-3 m/s	N	890	1560	2660
at speed > 3 m/s	N	550	1030	1940
Basic torque (without load)	Nm	1.2	2.2	3.2
Mass: basic weight/per m stroke/moved	kg	3.8/4.3/1.0	7.7/6.7/1.9	22.6/15.2/4.7
Max. permissible drive torque < 1 m/s	Nm	31	71	174
at speed 1-3 m/s	Nm	25	60	148
at speed > 3 m/s	Nm	16	39	108
Linear route per motor revolution	mm	180	240	350
Max. rotary speed of the drive axle	min ⁻¹	3000	2500	1700
Repeat accuracy	mm/m	+/-0.05	+/-0.05	+/-0.05
Positioning accuracy*	mm/m	+/-0.15	+/-0.15	+/-0.15
Run accuracy	mm	+/-0.03/300	+/-0.03/300	+/-0.03/300

*depends on various factors